

USW-Industrial Quick Start Guide



Click for
Table of Contents



tents



UniFi Switch



Screws (Qty. 6)



Screw Anchors (Qty. 6)



Power Cord

Installation Requirements

- Drill with 6 mm drill bit
- Phillips screwdriver
- Cat5/6 UTP cable for indoor installations. Plenum-rated cabling for plenum spaces.

System Requirements

- Linux, Mac OS X, or Microsoft Windows 7/8/10
- Java Runtime Environment 1.8 or above recommended
- Web Browser: Google Chrome (Other browsers may have limited functionality)
- UniFi Controller software v5.10.x (or newer), available at: ui.com/download/unifi

Hardware Overview

USW-Industrial Quick Start Guide



Click for Table of Contents

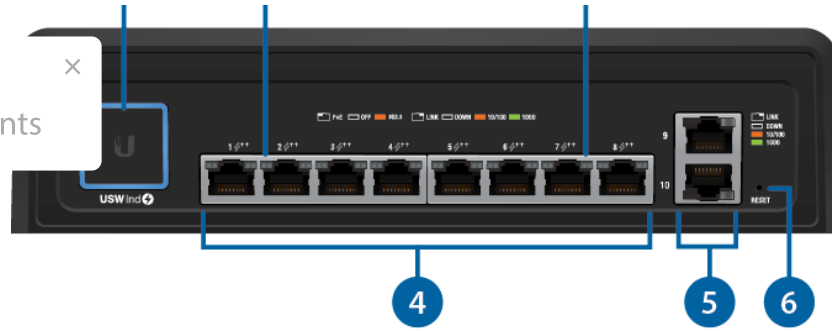

1 System LED	
Flashing White	Initializing.
Steady White	Factory defaults, waiting for adoption.
Alternating White/Blue	Device is busy; do not touch or unplug it. This usually indicates that a process such as a firmware upgrade is taking place.
Steady Blue	Successfully adopted by a network and working properly.
Flashing Blue	This is used to locate a device. When you click Locate in the UniFi Controller software, the System LED will flash blue. The software will also display the location of the UniFi Switch on the map.
2 PoE LED	
Off	PoE Disabled
Amber	802.3af/at/bt PoE
3 Link/Speed/Activity LED	
Off	No Link
Amber	Link Established at 10 or 100 Mbps Flashing Indicates Activity
Green	Link Established at 1000 Mbps (1 Gbps) Flashing Indicates Activity
4 Ports 1 - 8	

USW-Industrial Quick Start Guide

Click for
Table of Contents

×

10/100/1000 Ethernet connections.

6 Reset Button

This button serves two functions for the UniFi Switch:

- **Restart** Press and release the Reset button quickly.
- **Restore to Factory Default Settings** Press and hold the Reset button for more than five seconds.

Hardware Installation

You have two options for mounting:

- **Screws and Screw Anchors** You can use the included Screws and Screw Anchors. Go to "[Wall Mounting](#)".
- **Machine Screws** You can use eight M4 machine screws (not included), which must be long enough to extend 6 mm into the Switch.

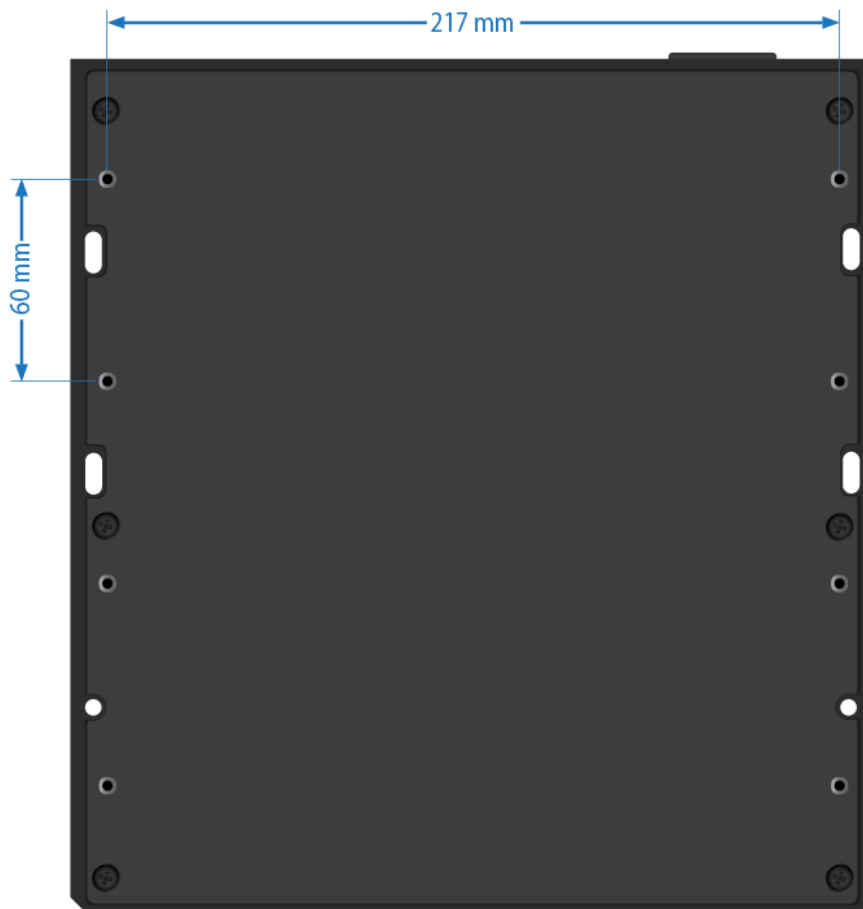

Wall Mounting

1.

USW-Industrial Quick Start Guide



Click for
Table of Contents

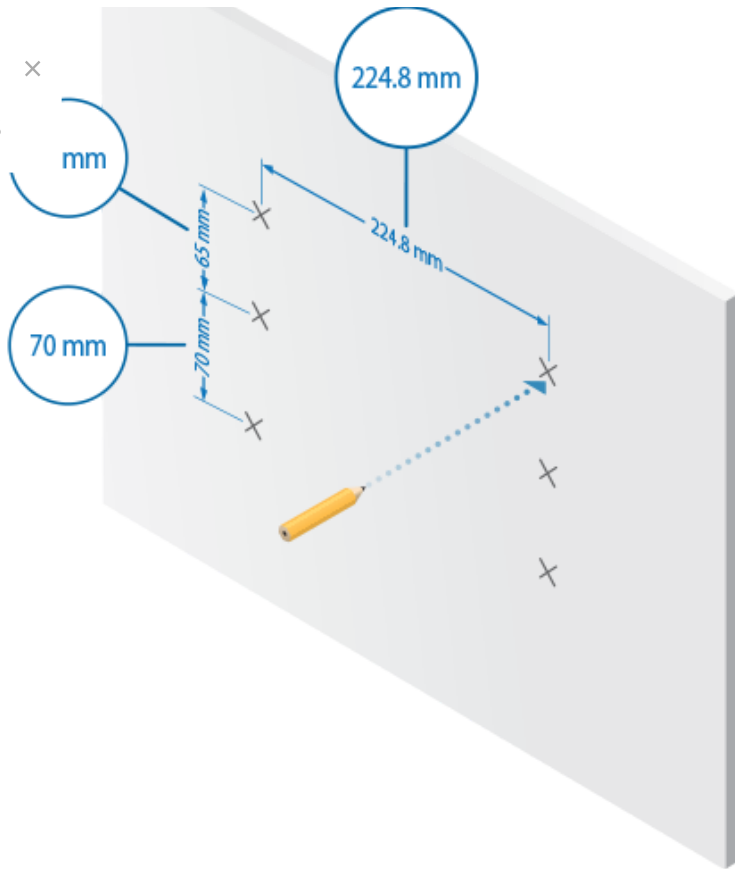

2.

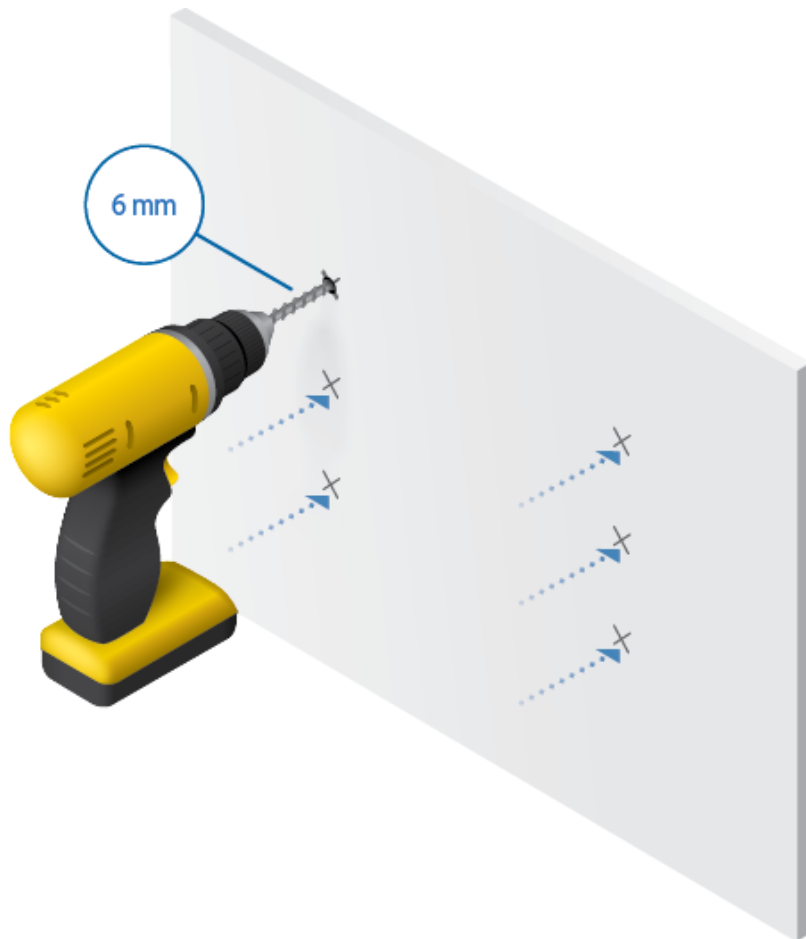

3.



USW-Industrial Quick Start Guide

Click for
Table of Contents

×

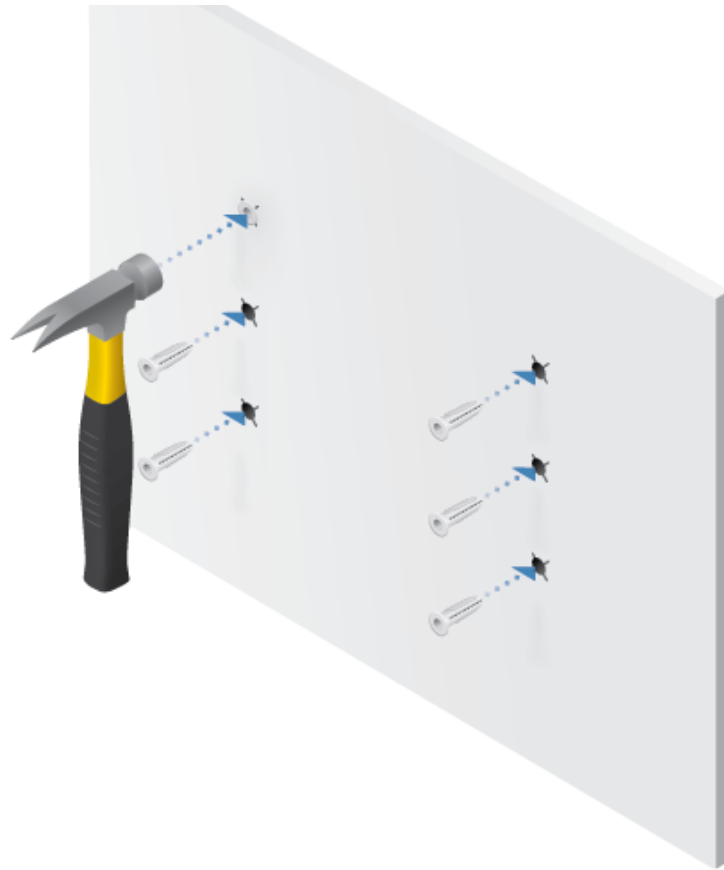

4.

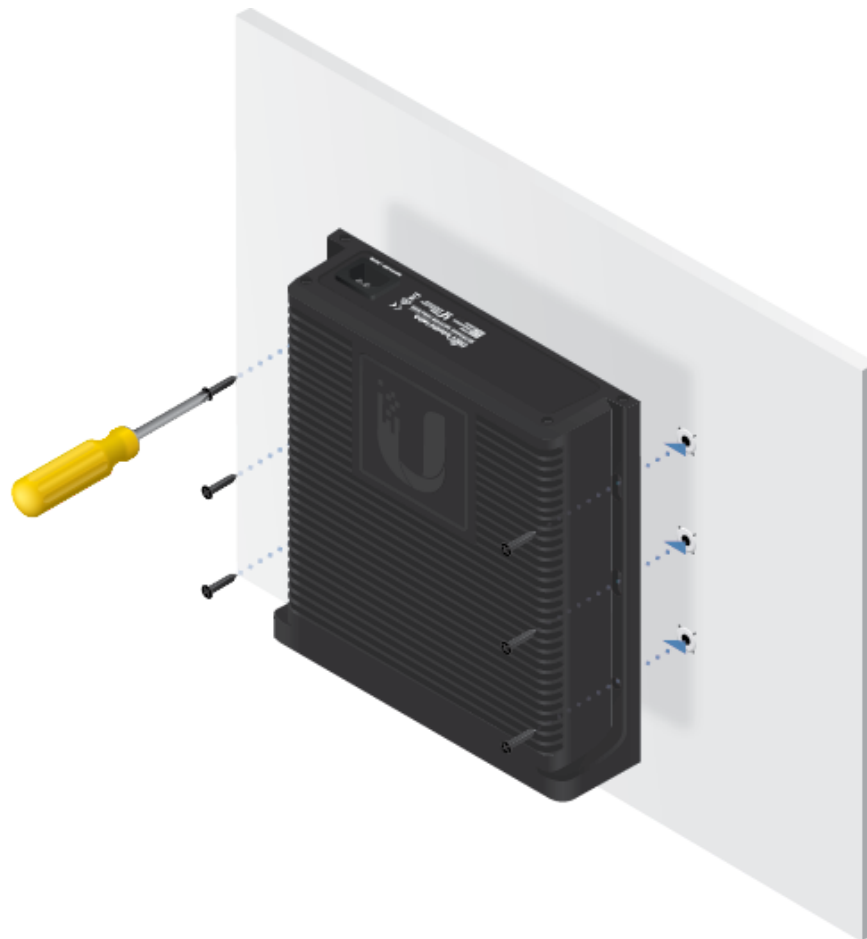

Connecting Power



USW-Industrial Quick Start Guide

Click for
Table of Contents



Connecting Ethernet

1.



2.



Software Installation

USW-Industrial Quick Start Guide



Click for
Table of Contents

× already have UniFi Controller v5.10.x or newer installed, skip to [the UniFi Switch](#)".

After you have installed the software and run the UniFi Installation Wizard, a login screen will appear for the UniFi Controller management interface. Enter the admin name and password that you created and click Sign In.

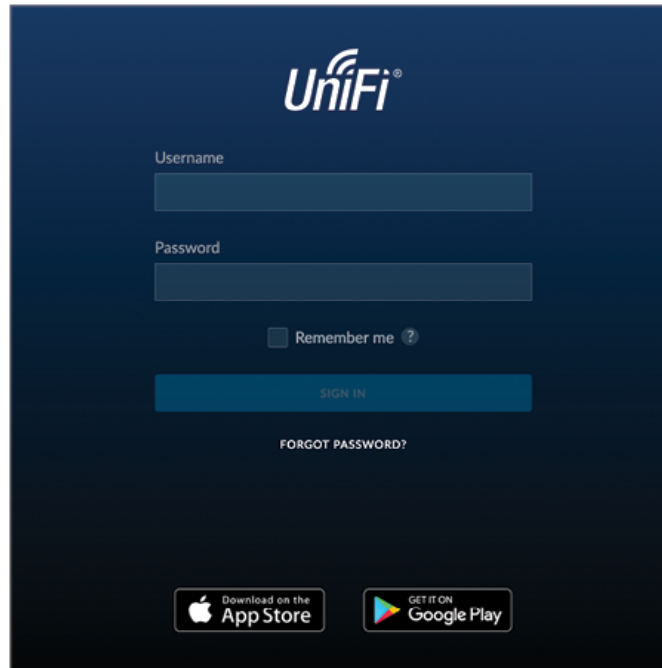

You can manage your network and view network statistics using the UniFi Controller management interface.

To adopt the UniFi Switch, proceed to ["Adopting the UniFi Switch"](#).

For information on configuring and using the UniFi Controller software, refer to the User Guide on the website: ui.com/download/unifi

Adopting the UniFi Switch

1. From the UniFi Controller dashboard, click Devices in the left menu bar.

USW-Industrial Quick Start Guide



Click for Table of Contents

2. On the Devices screen, locate the UniFi Switch in the list of devices under the Model column. To adopt the UniFi Switch, click Adopt.

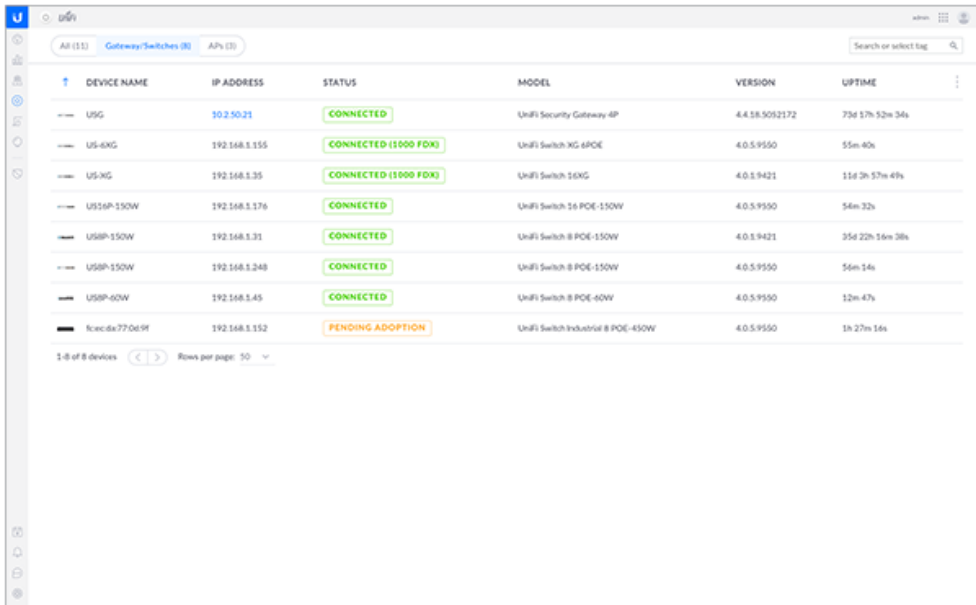

3. The System LED on the UniFi Switch will turn blue to confirm that it has been successfully adopted.

Specifications

USW-Industrial	
Dimensions	254 x 235 x 60 mm (10 x 9.25 x 2.36")
Weight	3.85 kg (8.49 lb)
Interfaces	
Networking	(8) 10/100/1000 802.3bt PoE RJ45 Ports (2) 10/100/1000 RJ45 Ports
Management	Ethernet In-Band

USW-Industrial Quick Start Guide

Power Method	100 to 240 VAC, 50/60 Hz Universal Input
AC/DC, Internal, 450W DC	
AC Input: 100 to 240VAC, Max. 6A	
Max. Power Consumption (Excluding PoE Output)	20W
LEDs	Status
System	PoE, Speed/Link/Activity
RJ45 Ports	
ESD/EMP Protection	Air: ± 24 kV, Contact: ± 24 kV
Shock and Vibration	ETSI300-019-1.4 Standard
Operating Temperature	
Internal AC/DC @ 450W	-40 to 50° C (-40 to 122° F)
Internal AC/DC @ 240W	-40 to 60° C (-40 to 140° F)
Operating Humidity	5 to 95% Noncondensing
Certifications	CE, FCC, IC

Safety Notices

1. Read, follow, and keep these instructions.
2. Heed all warnings.
3. Only use attachments/accessories specified by the manufacturer.



WARNING: Failure to provide proper ventilation may cause fire hazard. Keep at least 20 mm of clearance next to the ventilation holes for adequate airflow.



WARNING: To reduce the risk of fire or electric shock, do not expose this product to rain or moisture.



WARNING: Do not use this product in location that can be submerged by water.



WARNING: Avoid using this product during an electrical storm. There may be a remote risk of electric shock from lightning.

Electrical Safety Information

1. Compliance is required with respect to voltage, frequency, and current requirements indicated on the manufacturer’s label. Connection to a different power source than those specified may result in improper operation, damage to the equipment or pose a fire hazard if the limitations are not followed.
2. There are no operator serviceable parts inside this equipment. Service should be provided only by a qualified service technician.

USW-Industrial Quick Start Guide



- a. Do not substitute the power cord with one that is not the provided approved type. Never plug to connect to a 2-wire outlet as this will defeat the continuity of the

Click for

Table of Contents

requires the use of the ground wire as a part of the safety certification, modification or misuse can provide a shock hazard that can result in serious injury or death.

- c. Contact a qualified electrician or the manufacturer if there are questions about the installation prior to connecting the equipment.
- d. Protective earthing is provided by Listed AC adapter. Building installation shall provide appropriate short-circuit backup protection.
- e. Protective bonding must be installed in accordance with local national wiring rules and regulations.

Limited Warranty

ui.com/support/warranty

The limited warranty requires the use of arbitration to resolve disputes on an individual basis, and, where applicable, specify arbitration instead of jury trials or class actions.

Compliance

FCC

Changes or modifications not expressly approved by the party responsible for compliance could void the user's authority to operate the equipment.

This device complies with Part 15 of the FCC Rules. Operation is subject to the following two conditions.

1. This device may not cause harmful interference, and
2. This device must accept any interference received, including interference that may cause undesired operation.

This equipment has been tested and found to comply with the limits for a Class A digital device, pursuant to Part 15 of the FCC Rules. These limits are designed to provide reasonable protection against harmful interference when the equipment is operated in a commercial environment. This equipment generates, uses, and can radiate radio frequency energy and, if not installed and used in accordance with the instruction manual, may cause harmful interference to radio communications. Operations of this equipment in a residential area is likely to cause harmful interference in which case the user will be required to correct the interference at his own expense.

ISED Canada

CAN ICES-3(A)/NMB-3(A)

Australia and New Zealand



Warning: This equipment is compliant with Class A of CISPR 32. In a residential environment this equipment may cause radio interference.

CE Marking



Click for ×
Table of Contents

[WEEE Compliance Statement](#)

[Declaration of Conformity](#)

Online Resources



© 2019 Ubiquiti Inc. All rights reserved.